

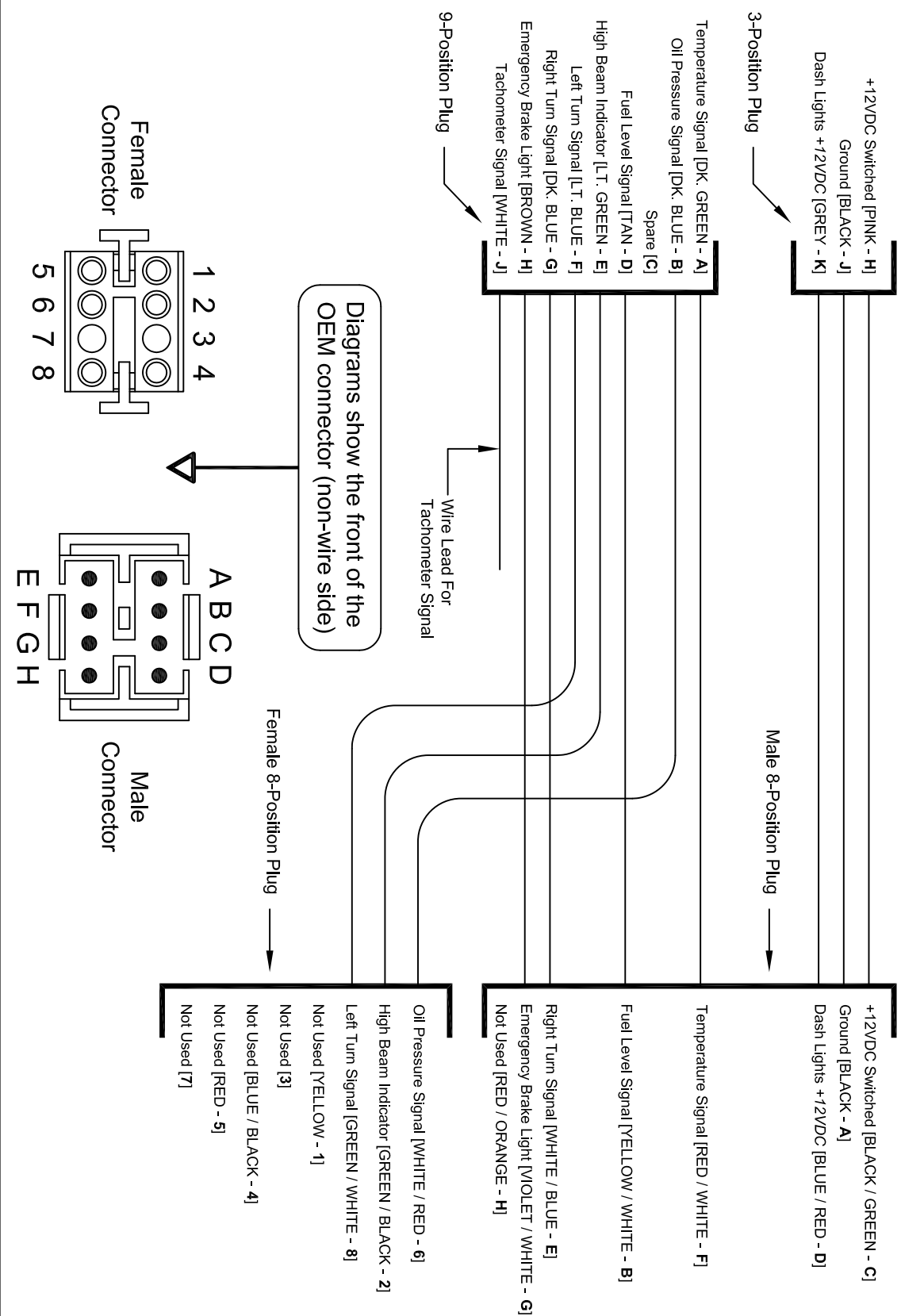

**Classic Instruments Harness**

**OEM Harnesses**



 <p><b>Classic Instruments</b></p> <p>1299 M75 South - Boyne City, Michigan 49712</p>	Part Name	1968 Mustang Instrument Panel
	Description	OEM Harness Adapter
Date	03/26/07	CAD DESIGNER Jake Bernthal